

1 LAYOUT PLAN  
L-3 SCALE 1 : 200

**LEGEND**

- PROPERTY LINE
- LIMIT OF WORK
- PROPOSED BACK OF CURB
- IRRIGATION
- 2" IRRIGATION PIPE (SUPPLY)
- 2" IRRIGATION PIPE (SPRINKLER)
- HOSE BIBS
- IRRIGATION PIT
- TORO P220 2" ELEC. SOL. VL.
- TORO SS 2001 ADI ROTOR 12-15 LPM

**NOTES**

1. LAYOUT TO BE APPROVED BY C.A. PRIOR TO CONSTRUCTION.
2. CENTRE OF PILE FOR STITTSVILLE LIGHT TO BE LOCATED 0.8m FROM BACK OF STREET CURB.

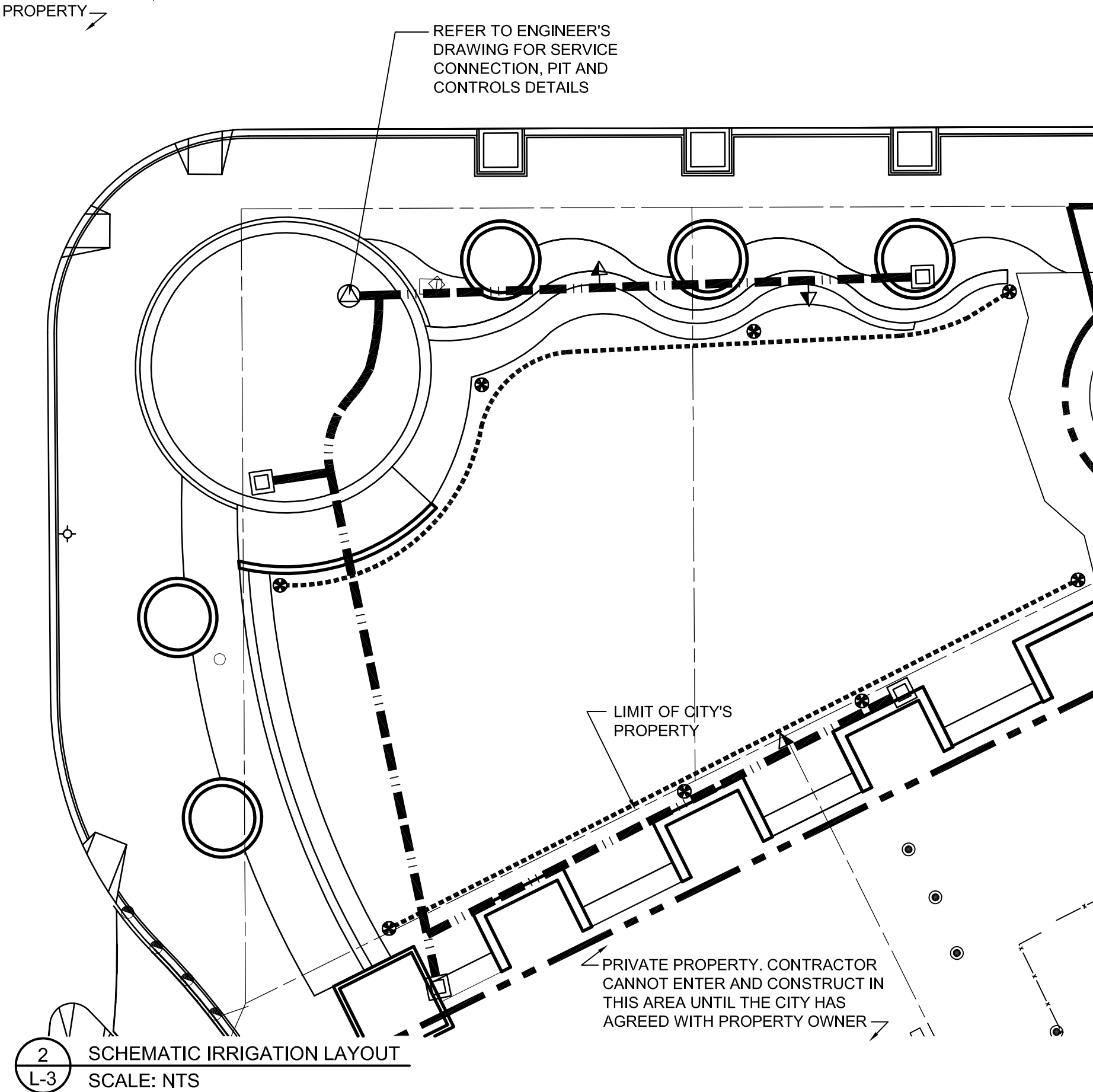

2 SCHEMATIC IRRIGATION LAYOUT  
L-3 SCALE: NTS

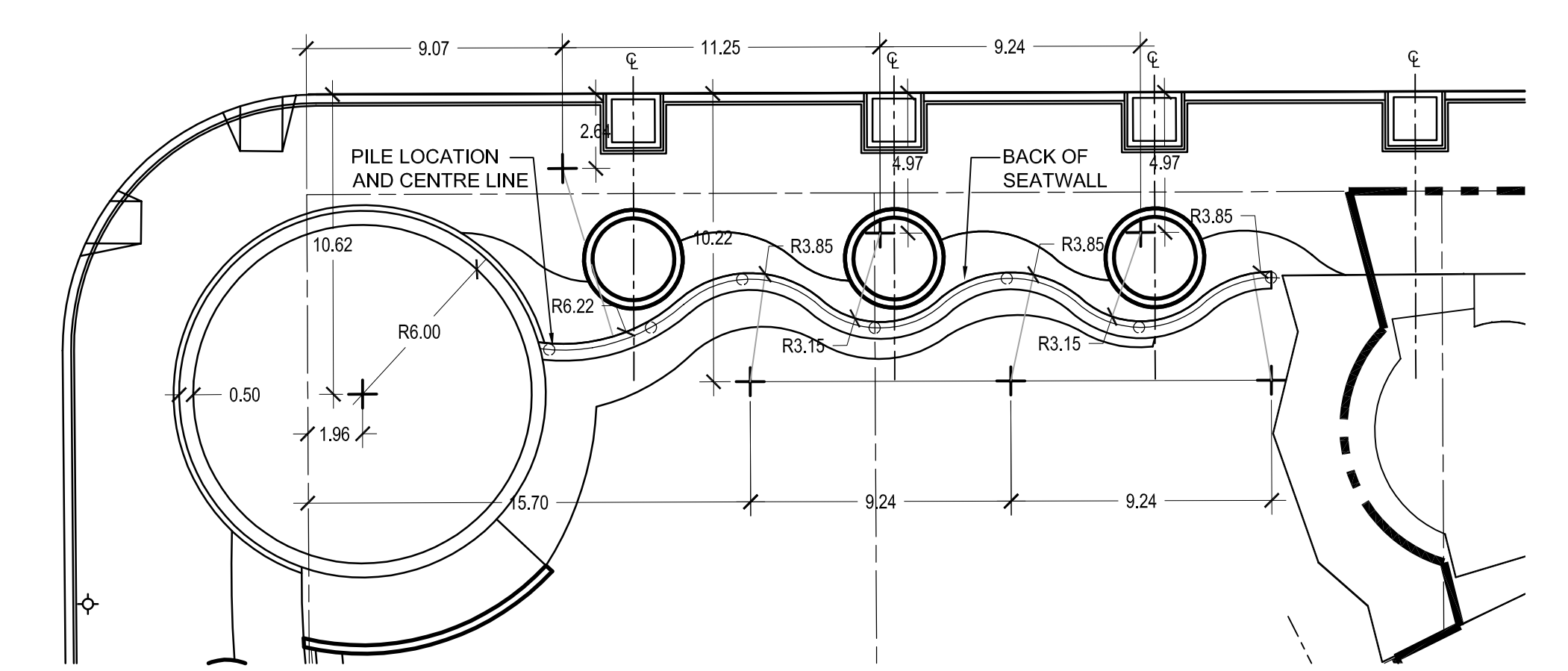

3 KING STREET- FORMED CONCRETE SEATING WALL LAYOUT  
L-3 SCALE: NTS

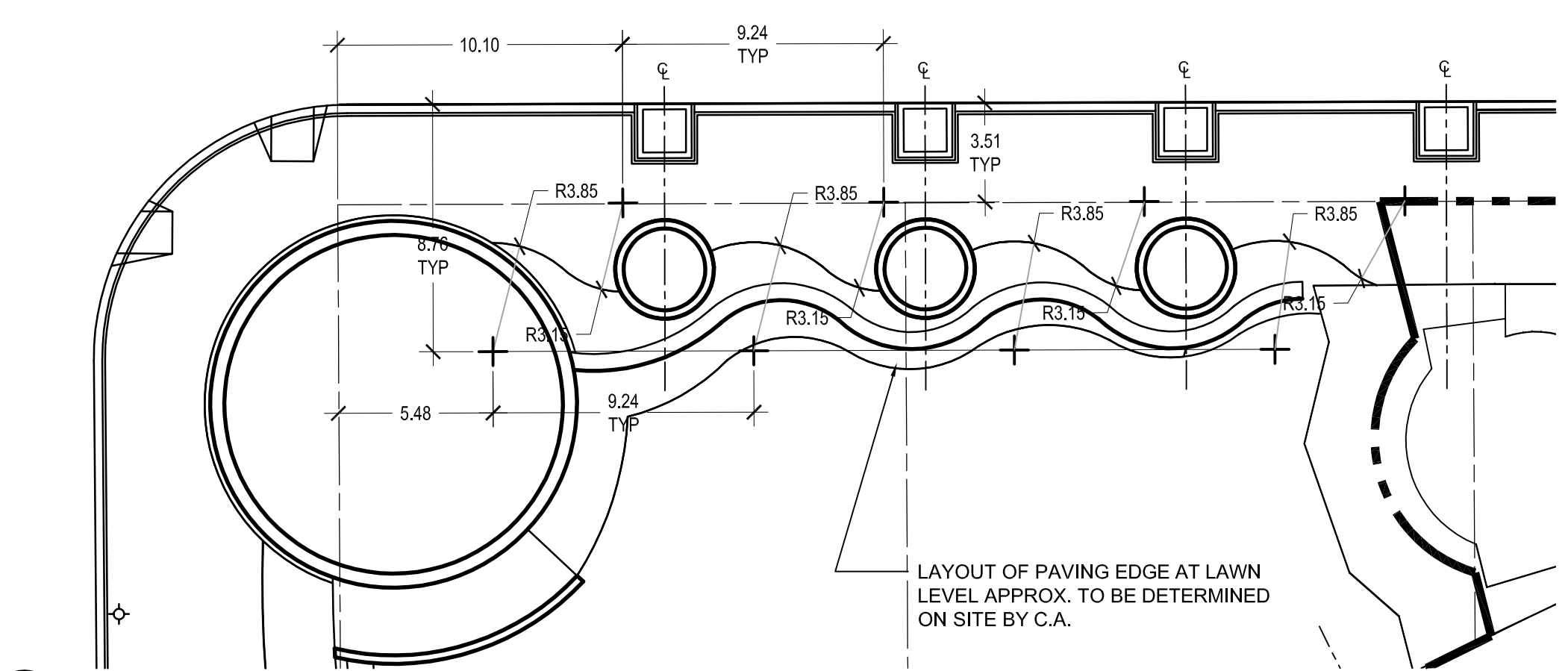

4 KING STREET- SIDEWALK PAVING LAYOUT  
L-3 SCALE: NTS

S:\projects\murray\projects\2008\Projects\8014 - King Street & Old Market Square\CAD\Construction\_Rig\Drawings\8014\_L-3\_LAYOUT.dwg 7/14/2008 11:44 AM By: SMM

150 WM	WATERMAIN	150 WM	HYDRO	150 WM	WATERMAIN	150 WM
HYDRANT	VALVE	300 LDS	LAND DRAINAGE SEWER	250 WWS	WASTE WATER SEWER	250 WWS
MANHOLE	CATCH BASIN	CURB INLET	JUNCTIONS	CULVERT	GAS	EXISTING
CONCRETE	ASPHALT	SIDEWALK	PROPERTY LINE	SURVEY BAR	DITCH	ELEVATION
HYDRANT, VALVE	CONCRETE	ASPHALT	PROPERTY LINE	SURVEY BAR	DITCH	ELEVATION
LAND DRAINAGE SEWER	LAND DRAINAGE SEWER	WASTE WATER SEWER	NORTH OR WEST GUTTER	SOUTH OR EAST GUTTER	NORTH OR WEST P L	SOUTH OR EAST P L
WASTE WATER SEWER	WASTE WATER SEWER	WASTE WATER SEWER	NORTH OR WEST GUTTER	SOUTH OR EAST GUTTER	NORTH OR WEST P L	SOUTH OR EAST P L
MANHOLE	CATCH BASIN	CURB INLET	NORTH OR WEST GUTTER	SOUTH OR EAST GUTTER	NORTH OR WEST P L	SOUTH OR EAST P L
JUNCTIONS	CULVERT	GAS	NORTH OR WEST GUTTER	SOUTH OR EAST GUTTER	NORTH OR WEST P L	SOUTH OR EAST P L
LEGEND-PLAN	PROPOSED	EXISTING	LEGEND-PLAN	PROPOSED	EXISTING	LEGEND-PROFILE
LEGEND-PLAN	PROPOSED	EXISTING	LEGEND-PLAN	PROPOSED	EXISTING	LEGEND-PROFILE

**LOCATION APPROVED UNDERGROUND STRUCTURES**

SUPV. U/G STRUCTURES COMMITTEE DATE

NOTE: LOCATION OF UNDERGROUND STRUCTURES AS SHOWN ARE BASED ON THE BEST INFORMATION AVAILABLE BUT NO GUARANTEE IS GIVEN THAT ALL EXISTING UTILITIES ARE SHOWN OR THAT THE GIVEN LOCATIONS ARE EXACT. CONFIRMATION OF EXISTENCE AND EXACT LOCATION OF ALL SERVICES MUST BE OBTAINED FROM THE INDIVIDUAL UTILITIES BEFORE PROCEEDING WITH CONSTRUCTION.

B.M. ELEV.			
NO.	REVISIONS	DATE	BY
0	ISSUED FOR TENDER	08.07.14	DM

**SCATLIFF + MILLER + MURRAY Inc.**

DESIGNED BY	CO / DM	CHECKED BY	DM
DRAWN BY	MBP / MB / WF	APPROVED BY	CO
HOR. SCALE:	AS NOTED	RELEASED FOR CONSTRUCTION:	
VERTICAL:		DATE	08.07.14

LANDSCAPE ARCHITECT'S SEAL  
ORIGINALLY SEALED BY  
DEREK MURRAY  
2008/07/14

CONSULTANT DRAWING NO.  
**L-3**

**THE CITY OF WINNIPEG**  
DEPARTMENT OF PLANNING  
PROPERTY AND DEVELOPMENT

**Winnipeg**

**KING STREET - RECONSTRUCTION  
OLD MARKET SQUARE - PHASE 1**

REDEVELOPMENT  
LAYOUT PLAN

SHEET **8** OF **16**  
CAD FILE DRAWING NUMBER  
8014\_L-3\_LAYOUT.dwg  
CITY DRAWING NUMBER  
**P-3295-07**