

Drawing Title:

Drawing No:

METAL SLAT WR:

Black Finish: Product # 52501064

Galvanized Finish: Product # 52501064GLV

**WASTE RECEPTACLE
SIDE OPENING METAL SLAT TYPE**

SCD-119A

SURFACE MOUNT

WIRE BASKET:

Black Finish: Product # 52501058

Galvanized Finish: Product # 52501058GLV

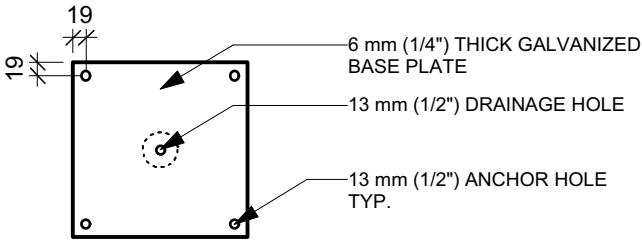

WR BASE PLATE

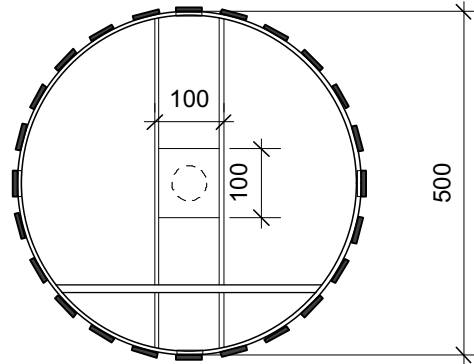

PLAN

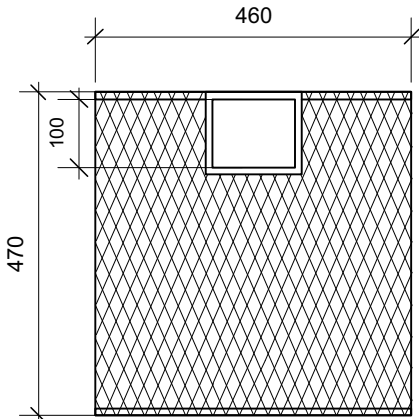

WIRE BASKET

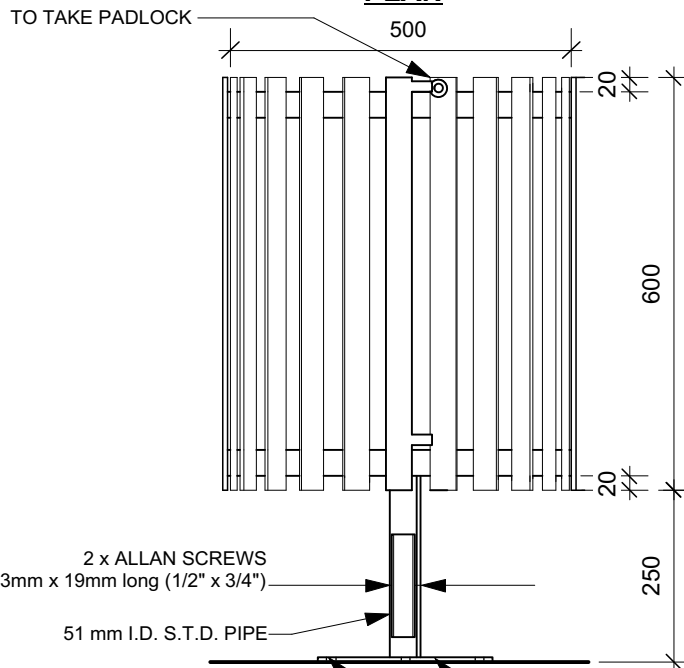

METAL SLAT WR

NOTE FOR BLACK FINISH:

- POWDERCOATED - METAL SUITABLY CLEANED TO REMOVE ANY GREASE, WAX, ETC. FOR PROPER PAINT BONDING TO OCCUR. BASE COAT ZINC RICH PRIMER. BAKED WITH A FINAL THICKNESS OF PAINT BETWEEN 5-8 MIL.

NOTE FOR GALVANIZED FINISH:

- METAL TO BE HOT DIPPED GALVANIZED.

DIMENSIONS SHOWN ARE IN MILLIMETRES UNLESS OTHERWISE SPECIFIED

DATE REVISION: June 21, 2018
SCALE: N.T.S.
DRAWN BY: LL

The City of Winnipeg
Planning, Property and Development Department
Planning and Land Use Division
Unit 15 - 30 Fort Street, Winnipeg, MB, R3C 4X5

