

## FORM N: DETAILED SPECIFICATIONS 21051

### HYBRID FAIRWAY MOWER (OPEN STATION)

#### 1.0 INSTRUCTIONS FOR COMPLETION OF SPECIFICATIONS

- 1.1 All items in these specifications should be answered indicating compliance or non-compliance.
- 1.2 **Bidders shall state “yes” for compliance or state “deviation”**, or give a reply where requested to do so. Deviations and/or equivalents shall be clearly stated and fully detailed. Deviations and/or equivalents will be considered subject to evaluation. In every instance where a brand name or design specifications is used, the City will also consider deviations and/or equivalents.
- 1.3 Lengthy explanations of deviations may be included in a separate document and must reference the appropriate Detailed Specification.
- 1.4 Each Bidder is required to fill in every blank. Failure to do so may be used as a basis for rejection of bid.
- 1.5 It will be the responsibility of the Bidder to inform the City of any errors or omissions in these Detailed Specifications, for under this Contract, the Contractor shall be held responsible to ensure that the manufacturer will be responsible for the design, performance, reliability and satisfactory operational function of the unit.

#### 2.0 DESCRIPTION OF EQUIPMENT

- 2.1 These specifications describe **Hybrid Fairway Mower** and other equipment and features as specified herein.
- 2.2 The **Hybrid Fairway Mower** shall be a new 2021 model year or newer.
- 2.3 The **Fairway Mower** and all other items/components shall be the manufacturer's latest model. The equipment shall be furnished complete and ready for operation. Any parts or accessories not specifically mentioned, but which are required to complete and place the equipment and associated attachments in successful operation shall be furnished as though specifically mentioned in these specifications. The equipment and associated attachments, and all parts thereof, shall conform in strength and quality of material and workmanship, to the best standards and engineering practice of the industry.
- 2.4 The **Hybrid Fairway Mower** shall be the manufacturer's latest model, as may be modified by these specifications. The **Hybrid Fairway Mower**, including all auxiliary equipment, shall be furnished complete and ready for use. All parts not specifically mentioned but which are required for the complete unit shall conform in strength, quality of material and workmanship, to the best standards and engineering practice in the industry.
- 2.5 The ratings specified herein merely state the minimum values acceptable to the City, not implying that those values are sufficient for the design of the particular equipment being bid.

#### 3.0 OTHER SPECIFICATIONS AND STANDARDS

- 3.1 All applicable SAE Standards form an integral part of the vehicle specifications and shall have precedence in any conflict concerning minimum acceptable standards.
- 3.2 The **Hybrid Fairway Mower** shall comply with the applicable regulations:

Transport Canada, National Safety Mark, NSM: <http://www.tc.gc.ca/eng/acts-regulations/acts-road.htm>

Manitoba Safety and Health Regulation, Parts 12, 16, 22: <https://web2.gov.mb.ca/laws/statutes/ccsm/w210e.php>

Canadian Motor Vehicle Safety Standards C.M.V.S.S. [http://laws-lois.justice.gc.ca/eng/regulations/C.R.C.,\\_c.\\_1038/section-sched3.html](http://laws-lois.justice.gc.ca/eng/regulations/C.R.C.,_c._1038/section-sched3.html)

Manitoba Highway Traffic Act regulations and requirements including, but not limited to, a Manitoba Government Inspection with Safety Sticker. <http://web2.gov.mb.ca/laws/regs/index.php?act=h60>

Canadian Standards Association, CSA: <http://www.csagroup.org/>

Under Writers of Canada, U/L: <http://www.ulc.ca/>

Society of Automotive Engineers, SAE: <http://www.sae.org/>

City of Winnipeg Lighting Visibility Standard: <http://winnipeg.ca/matmgt/pdfs/PublicWorksEquipLightingVisibility.pdf>

Manitoba Building Code: <https://web2.gov.mb.ca/laws/regs/current/pdf-regs.php?reg=31/2011>

- 3.3 All welding and welding designs of the load supporting elements shall conform to the requirements of the Canadian Standards Association Standard (CSA) W47.1-03 and W59-03.

#### 4.0 REFERENCES

- 4.1 Provide five (5) references where this equipment is used in a working environment where climatic conditions are similar to the City of Winnipeg.

---

---

---

---

---

#### 5.0 MAKE & MODEL

- 5.1 State year, make and model being bid: \_\_\_\_\_

#### 6.0 PERFORMANCE RELIABILITY

- 6.1 The responsibility for the design of the **Hybrid Fairway Mower**, its performance and reliability shall rest upon the Contractor.

- 6.2 The term “repeated failures” as used herein is defined to mean that the same component, subassembly, or assembly develops repeated defects, breakdowns and/or malfunctions rendering the vehicle inoperative, or requiring repeated shop correction, service and/or replacement during the warranty period applicable for said component, subassembly, of assembly. Minor items or ordinary service adjustments are not included, or considered under the scope of “repeated failures”, as well as other factors, such as operational damage due to accidents, misuse or lack of proper maintenance, service and lubrication attention by not following the manufacturer’s preventative maintenance schedule.

- 6.3 Where the **Hybrid Fairway Mower** develops “repeated failures” in service, the Contractor shall make any necessary engineering changes, repairs, alterations or modifications in order to guarantee reliability of performance.

- 6.4 The equipment shall be capable of consistent top performance in City of Winnipeg Environment. Note: The City of Winnipeg has four seasons with ambient temperatures ranging from approximately 90°F (32°C) to -40°F (-40°C).

#### 7.0 FUEL

- 7.1 Where applicable, all equipment must be fully fueled upon delivery (no exceptions).

#### 8.0 QUALIFICATIONS OF MANUFACTURER & CONTRACTOR

- 8.1 The manufacturer of the **Hybrid Fairway Mower** shall have five (5) years continuous experience manufacturing the equipment.

- 8.2 The manufacturer shall have in effect a documented quality control program ensuring that the quality of materials and workmanship, including welding, conforms to the best standards and engineering practice of the industry.

- 8.3 The Contractor shall have five (5) years continuous experience servicing, repairing and maintaining **Hybrid Fairway Mower** of the type being offered.

#### 9.0 SPECIFICATIONS:

**DIMENSIONS**

9.1	Overall height	Approx. 78-86 inches.	_____
9.2	Overall length	Approx. 105-121 inches.	_____
9.3	Mowing position width	Approx. 112 inches.	_____
9.4	Transport Width	Approx. 86-91 inches.	_____
9.5	Weight with cutting units	Approx. 2400-2800 lbs., <b>state.</b>	_____

**TRAVELING SPEEDS**

9.6	Forward speed max.	Approx. 16 km/h.	_____
9.7	Reverse speed max.	Approx. 8-11 km/h.	_____
9.8	Mowing Speed	Approx. 13 km/h.	_____

**ENGINE**

9.9	Engine type	Diesel, Tier IV interim or final, must meet current Emission Standards. Engine exhaust to be rear discharge. Engine hood to have prop rod or be tilt back past center type design.	_____
9.10	Torque	<b>State</b>	_____
9.11	Horsepower	Approx. Gross 24-26 HP.	_____
9.12	Cylinders	(3) cylinders.	_____
9.13	Cold weather start aid	Glow plugs.	_____
9.14	Cooling	Liquid.	_____
9.15	Air cleaner	Dual element dry type.	_____
9.16	Air restriction indicator	Gauge.	_____
9.17	Engine hood	Flanges guard in order to protect operator's hand.	_____

**FUEL**

9.18	Fuel capacity	Approx. 53L <b>State.</b>	_____
------	---------------	---------------------------	-------

**ELECTRICAL**

9.19	Alternator (engine)	Approx. 40 Amp alternator.	_____
9.20	Battery	12 volt approx. 570CCA.	_____
9.21	Engine shutoff	Electrically activated engine stop mechanism.	_____

9.22	Gauges	Electric fuel / engine temperature / hour meter / tachometer.	_____
9.23	Indicator lights	Glow plugs, electrical charge, engine oil pressure.	_____
9.24	Lockable power disconnect switch	Connected to battery. Prevents low-draw accessories from draining battery in long-term storage. Switch to be lockable with a pad lock.	_____

**DRIVE TRAIN/TRANSMISSION/STEERING**

9.25	Transmission type	Hydrostatic (forward & reverse).	_____
9.26	HST pedal (s)	Single or dual pedal, <b>state</b> .	_____
9.27	3-Wheel drive (3WD)	Fulltime.	_____
9.28	Traction drive	Hydraulic.	_____
9.29	Brakes	Hydrostatic or wet disc service brakes. Hand operated parking brake.	_____
9.30	Steering	Hydrostatic, with tilt, steering wheel.	_____

**TIRES**

9.31	Front	Smooth tire, no tread approx. 22x12-12 to 26.5x14-12 <b>state</b> size: _____	_____
9.32	Rear	Smooth tire, no tread approx. 22x12-12 to 24x13-12 <b>state</b> size: _____	_____
9.33	Tire make and model	<b>State:</b> _____	_____

**CUTTING UNIT**

9.34	Reel drive (electric)	Five (5) electrically driven cutting reels powered by four (4) 12V AGM lead carbon batteries.  Or  Five (5) electrically driven cutting reels powered by a 48Volt, 180 Amp alternator belt driven by the engine.	_____  _____  _____
9.35	Size of each cutting unit	Design to cut Kentucky Blue Grass. <b>State</b> size of cutting reels:_____	_____
9.36	Overall cutting width	Approx.100 inches. <b>State:</b> _____	_____

9.37	Height of cut range	0.25-1.5 inches.	_____
9.38	Reel speed	Electronically controlled, bidirectional variable reel speed for forward mowing and backwards for backlap operation.	_____
9.39	Bed Knife	<b>State</b> bed knife adjustment:	_____
9.40	Front and rear rollers	<b>State</b> Type/size:_____	_____
9.41	Scrapers	Front and rear roller scrapers	_____

**OPERATOR STATION/SAFETY EQUIPMENT**

9.42	ROPS (Roll Over Protection Structure)	Standard, certified, foldable.	_____
9.43	OPC	Operator's presence control required.	_____
9.44	Seat	Adjustable seat, with mechanical suspension.	_____
9.45	Seat belts	Retractable seat belt.	_____
9.46	Controls	Foot operated controls: Forward and reverse traction pedal(s), mow/transport speed limiter. Hand operated on control panel: Parking brake lever, ignition switch, engine throttle lever, work light switch, on/off switch for cutting units, joystick for cutting unit lift and lower. Other controls: Steering wheel tilt control, reel speed control, backlap engagement lever.	_____
9.47	Parking brakes	With warning indicator.	_____
9.48	Working lights	Two (2) LED.	_____

**10.0 OPERATOR STATION ERGONOMICS**

**Entry/ Exit**

10.1	First step entry height	<b>State</b> , height of first step in inches.	_____
10.2	First handhold entry height	<b>State</b> , first handhold entry height in inches.	_____
10.3	Access to equipment	<b>State</b> , door opening height in inches.	_____
10.4	Access to equipment	<b>State</b> , door opening width in inches.	_____
10.5	Designed to prevent slipping	Anti-slip steps/handholds <b>(Y or N)?</b>	_____

**Seat (use below diagram to answer questions)**

10.6

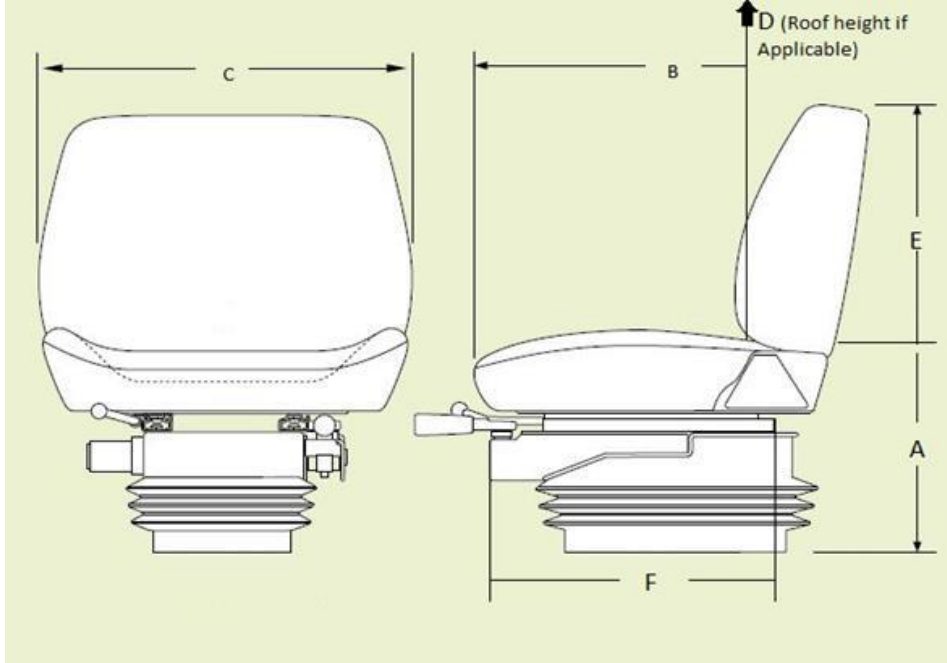

- |       |   |   |       |
|-------|---|---|-------|
| 10.7  | Sitting height range from floor (where feet rest) (A) | <b>State</b> , seat height range in inches.   | _____ |
| 10.8  | Seat length/depth (B)                                 | <b>State</b> , seat length/depth in inches.   | _____ |
| 10.9  | Seat width (C)  | <b>State</b> , seat width in inches.          | _____ |
| 10.10 | Cab height from seat to roof (if applicable) (D)      | <b>State</b> , cab height range in inches.    | _____ |
| 10.11 | Back rest height (E)                                  | <b>State</b> , back rest height in inches.    | _____ |
| 10.12 | Seat travel range (F)                                 | <b>State</b> , seat travel in inches.         | _____ |
| 10.13 | Lumbar support  | Is lumbar support provided ( <b>Y or N</b> )? | _____ |
| 10.14 | Head rest   | Is head rest provided ( <b>Y or N</b> )?      | _____ |
| 10.15 | Seat is made of breathable material                   | <b>State</b> , type of seat material.         | _____ |

**Cargo Area**

- |       |                                     |  |       |
|-------|-------------------------------------|--|-------|
| 10.16 | Lid opens to provide adequate space | Lid opens to provide adequate space.   | _____ |
| 10.17 | Loading height                      | <b>State</b> , trunk height in inches. | _____ |

**Environment**

- |       |  |   |       |
|-------|--|---|-------|
| 10.18 | Operator compartment is insulated from equipment noise (while operating) | <b>State</b> , dBA inside cab while operating.          | _____ |
| 10.19 | Operator insulated from equipment vibration                              | Is operator insulated from vibration ( <b>Y or N</b> )? | _____ |
| 10.20 | Heating/cooling systems  | <b>State</b> , cab temperature range.                   | _____ |

10.21 Cab lighting **State,** lumens inside cab. \_\_\_\_\_

11.0 **WARRANTY**

11.1 All warranty information shall be detailed and include all exclusions. The Contractor shall provide all published warranty information upon delivery of the equipment. Bidder shall state all warranty information.

11.2 Basic coverage **State:** \_\_\_\_\_

11.3 Powertrain **State:** \_\_\_\_\_

11.4 Hydraulics warranty **State:** \_\_\_\_\_

11.5 Batteries warranty **State:** \_\_\_\_\_

11.6 Tires warranty **State:** \_\_\_\_\_

11.7 Electrical warranty **State:** \_\_\_\_\_

12.0 **DELIVERY**

12.1 Delivery Point: The complete unit shall be serviced, ready for operation and delivered F.O.B. with the freight prepaid, including invoice and N.I.V.S. (if applicable) to the WFMA 185 Tecumseh Street, Winnipeg MB \_\_\_\_\_

12.2 Delivery Time: To be delivered within the approximate time frame **March 1 to 15, 2022**. Equipment shall be delivered between 8:00 am and 2:00 pm on Business Days. \_\_\_\_\_

12.3 Delivery Contact: The Contractor shall contact the Contract Administrator prior to delivery of the equipment. \_\_\_\_\_

12.4 P.D.I: A pre-delivery inspection shall be performed by the Contractor on the equipment. Proof upon inspection including completed check list \_\_\_\_\_

13.0 **MANUALS**

13.1 Manuals supplied under this contract. The manuals shall cover the complete equipment including all components thereof, CD or USD flash drive is preferred where available. \_\_\_\_\_

13.2 The following manuals shall be supplied with the units when delivered:

a) Operator's manual – Three (3) per unit (one operator manual shall be sent to the Equipment Operator Training Branch. \_\_\_\_\_

b) Parts and service manuals – one (1) complete sets including preventative maintenance schedules. CDs or USB flash drive are preferred. \_\_\_\_\_

14.0 **FIRST SERVICE PREVENTATIVE MAINTENANCE KIT**

- 14.1 In order to assure minimum downtime of the equipment in future service, the Contractor shall provide one (1) complete replacement set of new OEM filters for each unit purchased. The set of required filters shall include (if applicable to the equipment type) air, fuel, oil, cab and hydraulic, or otherwise all known necessary common replacement filters required for the first preventative maintenance servicing. \_\_\_\_\_
  
- 14.2 The Contractor shall provide a list of factory recommended lubricants to be used with the equipment, as well as a complete cross reference guide for all warranty approved lubricants and filters that can be used during preventative maintenance servicing. \_\_\_\_\_
  
- 15.0 **PARTS/LABOUR PRICING**
  
- 15.1 Bidder to provide City of Winnipeg Parts Discount % Pricing from retail parts pricing. **State percentage discount-** %\_\_\_\_\_
  
- 15.2 Bidder to provide City of Winnipeg Labor Discount % Pricing from Retail shop labor rate. **State percentage discount-** %\_\_\_\_\_



## FORM N: DETAILED SPECIFICATIONS 21052

### HYBRID GREENS MOWER (OPEN STATION)

#### 1.0 INSTRUCTIONS FOR COMPLETION OF SPECIFICATIONS

- 1.1 All items in these specifications should be answered indicating compliance or non-compliance.
- 1.2 **Bidders shall state “yes” for compliance or state “deviation”,** or give a reply where requested to do so. Deviations and/or equivalents shall be clearly stated and fully detailed. Deviations and/or equivalents will be considered subject to evaluation. In every instance where a brand name or design specifications is used, the City will also consider deviations and/or equivalents.
- 1.3 Lengthy explanations of deviations may be included in a separate document and must reference the appropriate Detailed Specification.
- 1.4 Each Bidder is required to fill in every blank. Failure to do so may be used as a basis for rejection of bid.
- 1.5 It will be the responsibility of the Bidder to inform the City of any errors or omissions in these Detailed Specifications, for under this Contract, the Contractor shall be held responsible to ensure that the manufacturer will be responsible for the design, performance, reliability and satisfactory operational function of the unit.

#### 2.0 DESCRIPTION OF EQUIPMENT

- 2.1 These specifications describe **Hybrid Greens Mower** and other equipment and features as specified herein.
- 2.2 The **Hybrid Greens Mower** shall be a new 2021 model year or newer.
- 2.3 The **Hybrid Greens Mower** and all other items/components shall be the manufacturer's latest model. The equipment shall be furnished complete and ready for operation. Any parts or accessories not specifically mentioned, but which are required to complete and place the equipment and associated attachments in successful operation shall be furnished as though specifically mentioned in these specifications. The equipment and associated attachments, and all parts thereof, shall conform in strength and quality of material and workmanship, to the best standards and engineering practice of the industry.
- 2.4 The **Hybrid Greens Mower** shall be the manufacturer's latest model, as may be modified by these specifications. The **Hybrid Greens Mower**, including all auxiliary equipment, shall be furnished complete and ready for use. All parts not specifically mentioned but which are required for the complete unit shall conform in strength, quality of material and workmanship, to the best standards and engineering practice in the industry.
- 2.5 The ratings specified herein merely state the minimum values acceptable to the City, not implying that those values are sufficient for the design of the particular equipment being bid.

#### 3.0 OTHER SPECIFICATIONS AND STANDARDS

- 3.1 All applicable SAE Standards form an integral part of the vehicle specifications and shall have precedence in any conflict concerning minimum acceptable standards.
- 3.2 The **Hybrid Greens Mower** shall comply with the applicable regulations:

Transport Canada, National Safety Mark, NSM: <http://www.tc.gc.ca/eng/acts-regulations/acts-road.htm>

Manitoba Safety and Health Regulation, Parts 12, 16, 22: <https://web2.gov.mb.ca/laws/statutes/ccsm/w210e.php>

Canadian Motor Vehicle Safety Standards C.M.V.S.S. [http://laws-lois.justice.gc.ca/eng/regulations/C.R.C.,\\_c.\\_1038/section-sched3.html](http://laws-lois.justice.gc.ca/eng/regulations/C.R.C.,_c._1038/section-sched3.html)

Manitoba Highway Traffic Act regulations and requirements including, but not limited to, a Manitoba Government Inspection with Safety Sticker. <http://web2.gov.mb.ca/laws/regs/index.php?act=h60>

Canadian Standards Association, CSA: <http://www.csagroup.org/>

Under Writers of Canada, U/L: <http://www.ulc.ca/>

Society of Automotive Engineers, SAE: <http://www.sae.org/>

City of Winnipeg Lighting Visibility Standard: <http://winnipeg.ca/matmgt/pdfs/PublicWorksEquipLightingVisibility.pdf>

Manitoba Building Code: <https://web2.gov.mb.ca/laws/regs/current/pdf-regs.php?reg=31/2011>

3.3 All welding and welding designs of the load supporting elements shall conform to the requirements of the Canadian Standards Association Standard (CSA) W47.1-03 and W59-03.

#### 4.0 REFERENCES

4.1 Provide five (5) references where this equipment is used in a working environment where climatic conditions are similar to the City of Winnipeg.

---

---

---

---

---

#### 5.0 MAKE & MODEL

5.1 State year, make and model being bid: \_\_\_\_\_

#### 6.0 PERFORMANCE RELIABILITY

6.1 The responsibility for the design of the **Hybrid Greens Mower**, its performance and reliability shall rest upon the Contractor.

6.2 The term “repeated failures” as used herein is defined to mean that the same component, subassembly, or assembly develops repeated defects, breakdowns and/or malfunctions rendering the vehicle inoperative, or requiring repeated shop correction, service and/or replacement during the warranty period applicable for said component, subassembly, of assembly. Minor items or ordinary service adjustments are not included, or considered under the scope of “repeated failures”, as well as other factors, such as operational damage due to accidents, misuse or lack of proper maintenance, service and lubrication attention by not following the manufacturer’s preventative maintenance schedule.

6.3 Where the **Hybrid Greens Mower** develops “repeated failures” in service, the Contractor shall make any necessary engineering changes, repairs, alterations or modifications in order to guarantee reliability of performance.

6.4 The equipment shall be capable of consistent top performance in City of Winnipeg Environment. Note: The City of Winnipeg has four seasons with ambient temperatures ranging from approximately 90°F (32°C) to -40°F (-40°C).

#### 7.0 FUEL

7.1 Where applicable, all equipment must be fully fueled upon delivery (no exceptions).

#### 8.0 QUALIFICATIONS OF MANUFACTURER & CONTRACTOR

8.1 The manufacturer of the **Hybrid Greens Mower** shall have five (5) years continuous experience manufacturing the equipment.

8.2 The manufacturer shall have in effect a documented quality control program ensuring that the quality of materials and workmanship, including welding, conforms to the best standards and engineering practice of the industry.

8.3 The Contractor shall have five (5) years continuous experience servicing, repairing and maintaining **Hybrid Greens Mower** of the type being offered.

#### 9.0 SPECIFICATIONS:

**DIMENSIONS**

9.1	Overall height	Approx. 78-80 inches.	_____
9.2	Overall length	Approx. 98-100 inches.	_____
9.3	Mowing position width	Approx. 71 inches.	_____
9.4	Wheel base	Approx. 47-51 inches.	_____
9.5	Weight with cutting units	Approx. 1200-1300 lbs., <b>state.</b>	_____

**TRAVELING SPEEDS**

9.6	Forward speed max.	Approx. 16 km/h.	_____
9.7	Reverse speed max.	Approx. 5-6 km/h.	_____
9.8	Mowing Speed	Approx. 8-10 km/h.	_____

**ENGINE**

9.9	Engine type	Gas with electronic throttle body fuel injection.	_____
9.10	Torque	<b>State</b>	_____
9.11	Horsepower	Approx. Gross 19-21 HP.	_____
9.12	Cylinders	(2) cylinders, <b>state.</b>	_____
9.13	Cooling	Air cooled.	_____
9.14	Air cleaner	Dual element dry type.	_____
9.15	Engine hood	Flanges guard in order to protect operator's hand.	_____

**FUEL**

9.16	Fuel capacity	Approx. 20L <b>State.</b>	_____
------	---------------	---------------------------	-------

**ELECTRICAL**

9.17	Alternator (engine)	Approx. 50 Amp alternator.	_____
9.18	Battery	12 volt approx. 300CCA.	_____
9.19	Engine shutoff	Electrically activated engine stop mechanism.	_____
9.20	Gauges	Electric fuel / engine temperature / hour meter / tachometer.	_____
9.21	Indicator lights	Electrical charge, engine oil pressure.	_____

9.22 Lockable power disconnect switch Connected to battery. Prevents low-draw accessories from draining battery in long-term storage. Switch to be lockable with a pad lock. \_\_\_\_\_

**DRIVE TRAIN/TRANSMISSION/STEERING**

9.23 Transmission type Hydrostatic (forward & reverse). \_\_\_\_\_

9.24 HST pedal (s) Single or dual pedal, **state**. \_\_\_\_\_

9.25 2 or 3-Wheel drive (2WD or 3WD) **State:**\_\_\_\_\_ \_\_\_\_\_

9.26 Traction drive Hydraulic. \_\_\_\_\_

9.27 Brakes Drum or disc service brakes. Hand operated parking brake. \_\_\_\_\_

9.28 Steering Hydrostatic, with tilt, steering wheel. \_\_\_\_\_

**TIRES**

9.29 Front Smooth tire, no tread approx. 19x10.5-8 to 20x10-10 **state** size: \_\_\_\_\_  
\_\_\_\_\_

9.30 Rear Smooth tire, no tread approx. 19x10.5-8 to 20x10-10 **state** size: \_\_\_\_\_  
\_\_\_\_\_

9.31 Tire make and model **State:** \_\_\_\_\_ \_\_\_\_\_

**CUTTING UNIT**

9.32 Reel drive (electric) Three (3) electrically driven cutting reels powered 48V-5400 watt generator in parallel with 48V 9Ah battery. \_\_\_\_\_

Or

Three (3) electrically driven cutting reels powered by a 56Volt, 100 Amp alternator belt driven by the engine. \_\_\_\_\_

9.33 Size of each cutting unit **State** size of cutting reels:\_\_\_\_\_ \_\_\_\_\_

9.34 Overall cutting width Approx. 60 inches. \_\_\_\_\_

9.35 Height of cut range 0.08-1.00 inches. \_\_\_\_\_

9.36 Bed Knife **State** bed knife adjustment: \_\_\_\_\_  
\_\_\_\_\_

9.37	Reel speed	Electronically controlled, bidirectional variable reel speed for forward mowing and backwards for backlap operation.	_____
9.38	Rollers	<b>State</b> Type/size:_____	_____
9.39	Brushes	Powered rear roller brushes.	_____
9.40	Grass catchers	On each cutting unit.	_____

**OPERATOR STATION/SAFETY EQUIPMENT**

9.41	ROPS (Roll Over Protection Structure)	Standard two (2), certified.	_____
9.42	OPC	Operator's presence control required.	_____
9.43	Seat	Adjustable seat, with mechanical suspension.	_____
9.44	Seat belts	Retractable seat belt.	_____
9.45	Controls	Foot operated controls: Forward and reverse traction pedal(s), mow/transport speed limiter. Hand operated on control panel: Parking brake lever, ignition switch, engine throttle lever, work light switch, on/off switch for cutting units, joystick for cutting unit lift and lower. Other controls: Steering wheel tilt control, reel speed control, backlap engagement lever.	_____
9.46	Parking brakes	With warning indicator.	_____
9.47	Working lights	Two (2) LED.	_____

10.0 **OPERATOR STATION ERGONOMICS**

**Entry/ Exit**

10.1	First step entry height	<b>State</b> , height of first step in inches.	_____
10.2	First handhold entry height	<b>State</b> , first handhold entry height in inches.	_____
10.3	Access to equipment	<b>State</b> , door opening height in inches.	_____
10.4	Access to equipment	<b>State</b> , door opening width in inches.	_____
10.5	Designed to prevent slipping	Anti-slip steps/handholds <b>(Y or N)?</b>	_____

**Seat (use below diagram to answer questions)**

10.6

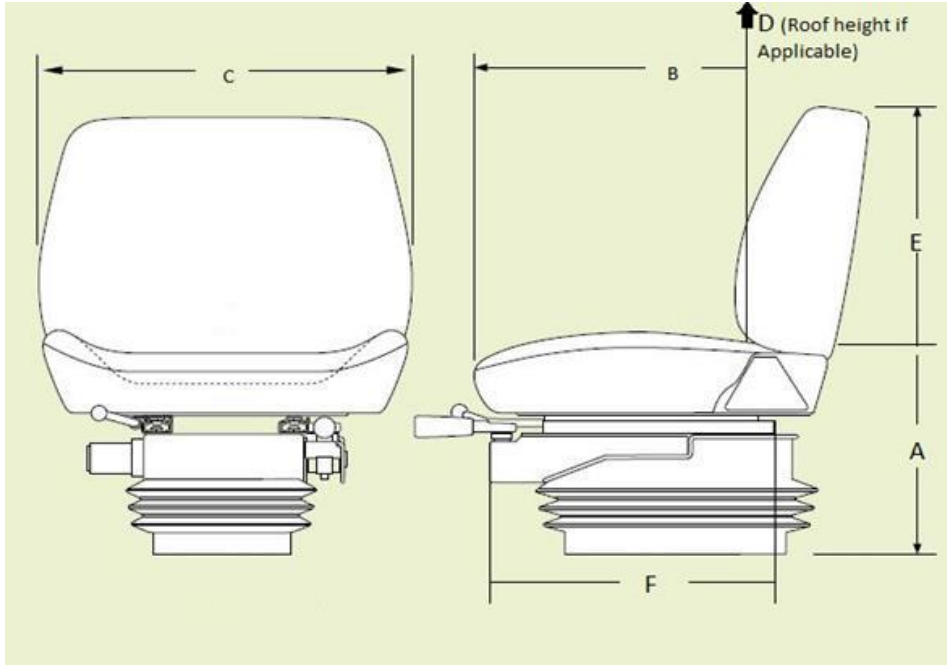

- |       |   |   |       |
|-------|---|---|-------|
| 10.7  | Sitting height range from floor (where feet rest) (A) | <b>State</b> , seat height range in inches.   | _____ |
| 10.8  | Seat length/depth (B)                                 | <b>State</b> , seat length/depth in inches.   | _____ |
| 10.9  | Seat width (C)  | <b>State</b> , seat width in inches.          | _____ |
| 10.10 | Cab height from seat to roof (if applicable) (D)      | <b>State</b> , cab height range in inches.    | _____ |
| 10.11 | Back rest height (E)                                  | <b>State</b> , back rest height in inches.    | _____ |
| 10.12 | Seat travel range (F)                                 | <b>State</b> , seat travel in inches.         | _____ |
| 10.13 | Lumbar support  | Is lumbar support provided ( <b>Y or N</b> )? | _____ |
| 10.14 | Head rest   | Is head rest provided ( <b>Y or N</b> )?      | _____ |
| 10.15 | Seat is made of breathable material                   | <b>State</b> , type of seat material.         | _____ |

**Cargo Area**

- |       |                                     |  |       |
|-------|-------------------------------------|--|-------|
| 10.16 | Lid opens to provide adequate space | Lid opens to provide adequate space.   | _____ |
| 10.17 | Loading height                      | <b>State</b> , trunk height in inches. | _____ |

**Environment**

- |       |  |   |       |
|-------|--|---|-------|
| 10.18 | Operator compartment is insulated from equipment noise (while operating) | <b>State</b> , dBA inside cab while operating.          | _____ |
| 10.19 | Operator insulated from equipment vibration                              | Is operator insulated from vibration ( <b>Y or N</b> )? | _____ |
| 10.20 | Heating/cooling systems  | <b>State</b> , cab temperature range.                   | _____ |

10.21 Cab lighting **State**, lumens inside cab. \_\_\_\_\_

11.0 **WARRANTY**

11.1 All warranty information shall be detailed and include all exclusions. The Contractor shall provide all published warranty information upon delivery of the equipment. Bidder shall state all warranty information.

11.2 Basic coverage **State:** \_\_\_\_\_

11.3 Powertrain **State:** \_\_\_\_\_

11.4 Hydraulics warranty **State:** \_\_\_\_\_

11.5 Batteries warranty **State:** \_\_\_\_\_

11.6 Tires warranty **State:** \_\_\_\_\_

11.7 Electrical warranty **State:** \_\_\_\_\_

12.0 **DELIVERY**

12.1 Delivery Point: The complete unit shall be serviced, ready for operation and delivered F.O.B. with the freight prepaid, including invoice and N.I.V.S. (if applicable) to the WFMA 185 Tecumseh Street, Winnipeg MB \_\_\_\_\_

12.2 Delivery Time: To be delivered within the approximate time frame **March 1 to 15, 2022**. Equipment shall be delivered between 8:00 am and 2:00 pm on Business Days. \_\_\_\_\_

12.3 Delivery Contact: The Contractor shall contact the Contract Administrator prior to delivery of the equipment. \_\_\_\_\_

12.4 P.D.I: A pre-delivery inspection shall be performed by the Contractor on the equipment. Proof upon inspection including completed check list \_\_\_\_\_

13.0 **MANUALS**

13.1 Manuals supplied under this contract. The manuals shall cover the complete equipment including all components thereof, CD or USD flash drive is preferred where available. \_\_\_\_\_

13.2 The following manuals shall be supplied with the units when delivered:

a) Operator's manual – Three (3) per unit (one operator manual shall be sent to the Equipment Operator Training Branch. \_\_\_\_\_

b) Parts and service manuals – one (1) complete sets including preventative maintenance schedules. CDs or USB flash drive are preferred. \_\_\_\_\_

14.0 **FIRST SERVICE PREVENTATIVE MAINTENANCE KIT**

14.1 In order to assure minimum downtime of the equipment in future service, the Contractor shall provide one (1) complete replacement set of new OEM filters for each unit purchased. The set of required filters shall include (if applicable to the equipment type) air, fuel, oil, cab and hydraulic, or otherwise all known necessary common replacement filters required for the first preventative maintenance servicing. \_\_\_\_\_

14.2 The Contractor shall provide a list of factory recommended lubricants to be used with the equipment, as well as a complete cross reference guide for all warranty approved lubricants and filters that can be used during preventative maintenance servicing. \_\_\_\_\_

15.0 **PARTS/LABOUR PRICING**

15.1 Bidder to provide City of Winnipeg Parts Discount % Pricing from retail parts pricing. **State percentage discount-** %\_\_\_\_\_

15.2 Bidder to provide City of Winnipeg Labor Discount % Pricing from Retail shop labor rate. **State percentage discount-** %\_\_\_\_\_